

Enclosed Type Magnetic starter (Push Button Type)

封闭式起动器（按钮型）



型号说明 Type designation

UK	Q	22	MB	AC220V																																
科瑞普 KRIPAL	封闭式启动器 Enclosed type magnetic motor	额定电流 Rated current (AC 440V基准)	分类型 Application	操作电压 Operation voltage																																
	Q 特殊防护 Special Protection	<table border="1"> <tr><td>9</td><td>4KW</td><td>75</td><td>37KW</td></tr> <tr><td>12</td><td>5.5KW</td><td>85</td><td>45KW</td></tr> <tr><td>18</td><td>7.5KW</td><td>100</td><td>55KW</td></tr> <tr><td>22</td><td>11KW</td><td>125</td><td>60KW</td></tr> <tr><td>32</td><td>15KW</td><td>150</td><td>75KW</td></tr> <tr><td>40</td><td>18.5KW</td><td>180</td><td>90KW</td></tr> <tr><td>50</td><td>22KW</td><td>220</td><td>132KW</td></tr> <tr><td>65</td><td>30KW</td><td></td><td></td></tr> </table>	9	4KW	75	37KW	12	5.5KW	85	45KW	18	7.5KW	100	55KW	22	11KW	125	60KW	32	15KW	150	75KW	40	18.5KW	180	90KW	50	22KW	220	132KW	65	30KW			- 铁壳 Steel case B 铁壳带按钮 Steel case (push button type) M 塑料壳 Plastic case MB 塑料壳带按钮 Plastic case(push button type) 防护等级 Protection grade	与接触器一样 Same with the magnetic contactors
9	4KW	75	37KW																																	
12	5.5KW	85	45KW																																	
18	7.5KW	100	55KW																																	
22	11KW	125	60KW																																	
32	15KW	150	75KW																																	
40	18.5KW	180	90KW																																	
50	22KW	220	132KW																																	
65	30KW																																			
	W1 一般防护 General Protection																																			

额定容量 Rated capacity

型号 Model	额定容量 Rated capacity (KW)					额定电流 Rated current(A)			AC1类别 AC1 Type
	单相电机 Single-phase motor		三相电机AC3类别 Three-phase motor AC3 Type			三相电机AC3类别 Three-phase motor AC3 Type			
	110V	220V	200V~220V	380V~440V	500V~550V	200V~220V	380V~440V	500V~550V	
UKQ-9MB(UKW1-9MB)	0.4	0.8	2.5	4	4	11	9	7	25
UKQ-12MB(UKW1-12MB)	0.5	1	3.5	5.5	7.5	13	12	12	25
UKQ-18MB(UKW1-18MB)	0.75	1.5	4.5	7.5	7.5	18	18	13	40
UKQ-22MB(UKW1-22MB)	0.9	1.8	5.5	11	15	22	22	22	40
UKQ-32MB	1.2	-	7.5	15	18.5	32	32	28	50
UKQ-40MB	1.7	-	11	18.5	22	40	40	32	60
UKQ-50B	-	-	15	22	30	55	50	43	80
UKQ-65B	-	-	18.5	30	33	65	65	60	100
UKQ-75B	-	-	22	37	37	75	75	64	110
UKQ-85B	-	-	25	45	45	85	85	75	135

外型安装尺寸 External & Mounting dimensions

型号 Model	外形尺寸 External / mounting dimension
UKW1-9MB~22MB	

Enclosed Type Magnetic starter (Push Button Type)

封闭式起动器 (按钮型)

外型安装尺寸 External & Mounting dimensions

型号 Model	外形尺寸 External / mounting dimension		
UKQ-9MB~22MB			
UKQ-32MB~40MB			
UKQ-50B~85B			
触点构成 Contacts form			

UKQ-5CP Magnetic Starter

UKQ-5CP 电磁起动器



UKQ-5CP

适用范围 Application

UKQ-5CP 电磁起动器适用于交流50Hz或60Hz，额定电压至550V，额定控制功率至9KW的交流电机的直接启动与停止的控制，对笼型电动机的过载和断相起保护作用，并对电机有失压保护功能。

UKQ-5CP 电磁起动器符合IEC60947-4-1，及GB/T 14048.4标准。

The UKQ-5CP electromagnetic starter is to control the direct starting and stopping of AC motor of rated voltage of up to 550V, rated frequency of 50Hz or 60Hz, and rated control power of up to 9kW, and also protect the squirrel-cage type motor from open phase, overload, and no-voltage.

MXQ-5CP electrical magnetic staonter according to IEC60947-4-1 & GB/T 14048.4 Standard.

型号 Type	额定功率 Rated Power(kw)			额定电流 Rated current(A)			交流电 性能 AC 1 duty(A)	整定电流 Setting current(A)
	AC 3 duty			AC 3 duty				
	200V~ 220V	380V~ 440V	500V~ 550V	200V~ 220V	380V~ 440V	500V~ 550V		
UKQ-5CP	4	7.5	9	18	17	17	32	2-4,4-8,8-16
UKQ-5CPB	4	7.5	9	18	17	17	32	2-4,4-8,8-16

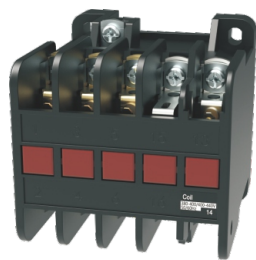

UKC-5

2-4A

4-8A

8-16A



UKT-5N

外型安装尺寸 External & Mounting dimensions

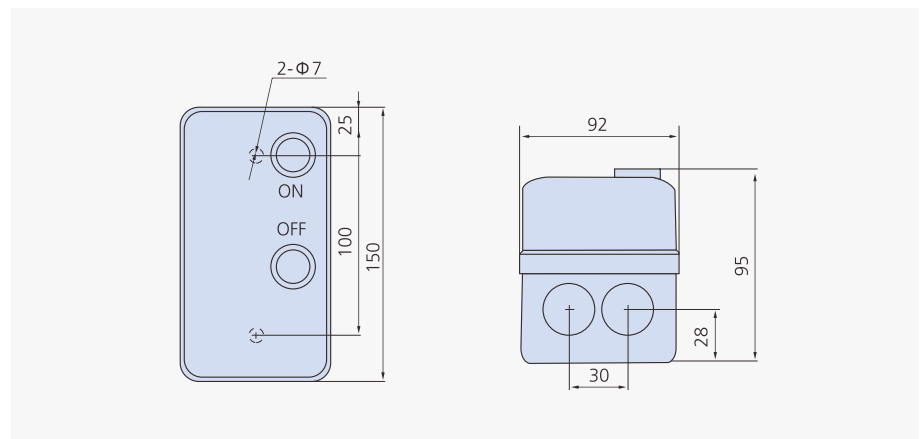

电气原理图 Diagram of electric principle

